



Control Units MAGTRONIC

Loop Detector MID 1

The MID Detector

The microprocessor-controlled, single-channel MID detector can detect vehicles without contact. Via the connected induction loop all sorts of metallic vehicles like cars, trucks, buses, fork lifts and even bicycles are easily detected.

The potentialfree outputs can either be used for presence registration, safety devices, counters or to open and close barriers and gates.

High sensitivity, rapid reaction time and maintained detection (i.e. unlimited occupation) are some of the advantages of the MID.

External interference is suppressed by special measuring methods.

Techniques

The complete unit is contained within a plastic housing.

Mounting is quick, easy and without problems due to the DIN rail mounting method.

Wiring connections are reliable with the labeled terminal strips. By means of the dip switch on the front panel, the frequency High/Low, the output pulse timing and the sensitivity of the loop may be adjusted.

The integrated LED display shows the detector operation modes; such as self tuning of the loop, presence of a vehicle and loop failure.

Connecting Loops

The induction loop must be connected to terminals 9 and 10. The inductance of the loop must be between 70 μ H and 1000 μ H.

Make sure that the loop connections are secure. One suggestion for trouble-free service is to put a little "Nolux" on the loop leads before connecting them. After connection of the loop the reset button must be pressed (tuning time: 15 sec. at maximum.)

After a power failure, the detector re-tunes automatically.

Frequency of the Loop

The upper dip switch sets the frequency of the induction loop, and can be increased = 'FH' or decreased = 'FL'.

If several induction loops are in close proximity to each other, make sure that the frequencies are different. This can be accomplished by connecting a small inductor in parallel with the loop across terminals 9 and 10.

Sensitivity of the Loop

By means of the dip switches '1' and '2', four different sensitivity levels between 'min.' and 'max.' can be chosen.

Functions

LED Display

The LED shows three different operation modes:

- Quick flashing light after power restoration; during the balancing after a reset of the unit.
- Continuous light when a vehicle is detected and remains on the loop.
- Slow flashing light during operation when there is a failure of the loop, the frequency is out of the admissible frequency range or the loop is not connected.

RESET Button

The reset button (tuning of the loop) must be pressed after every change in the dip switch position.

Contact 1 (presence)

Fail safe output. The output is inactive until the detector tunes up, and the loop functions properly. Terminal 6 and 7 is the normally closed presence output. Terminal 6 and 8 is the normally open presence output. The response time is about 150 ms.

Contact 2 (pulse)

Depending on the position of the dip switch '1' or '2', a potentialfree impulse (300 ms) is given at terminals 4 and 5, e.g. when entering '1' or leaving '2' the loop.

Technical Data:

	Type
Voltage	V
Frequency	Hz
Power consumption	VA
Range of inductivity	μ H
Response time	ms
Temperature influence	$^{\circ}$ C/h
Protection	IP
Weight	g

MID 1 A

230 AC
50-60
2
70-1000
150
30 $^{\circ}$ C/h
40
370

MID 1 C

115 AC
50-60
2
70-1000
150
30 $^{\circ}$ C/h
40
370

MID 1 E

24 DC
-
2
70-1000
150
30 $^{\circ}$ C/h
40
240

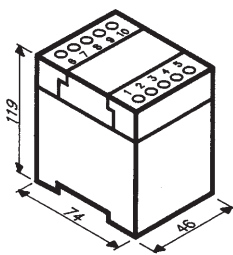

dimensions MID 1

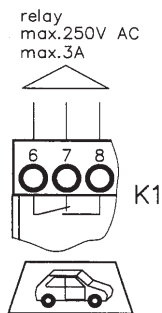

contact 1 = presence

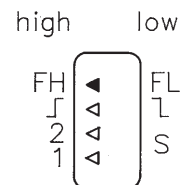

loop frequency

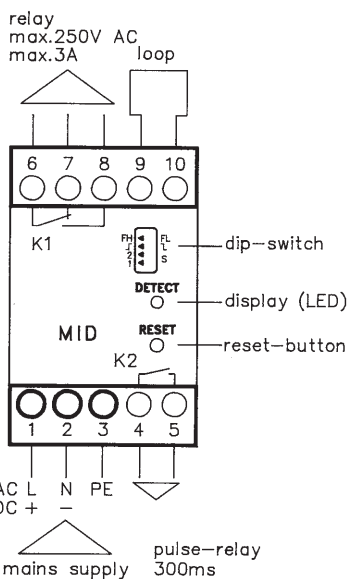

wiring diagram

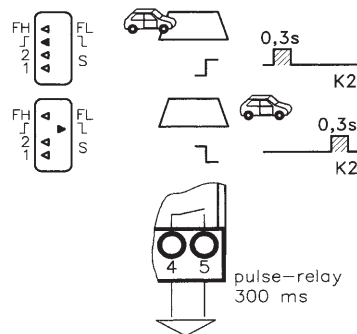

contact 2 = pulse

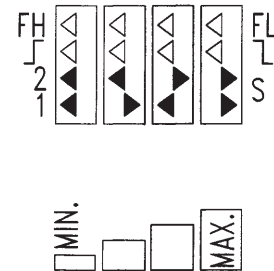

loop sensitivity